

1

2

3

4

A

B

C

D

A

B

C

D

会签栏
SIGN

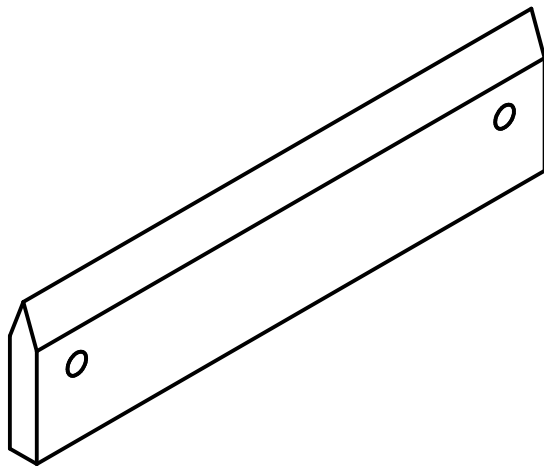
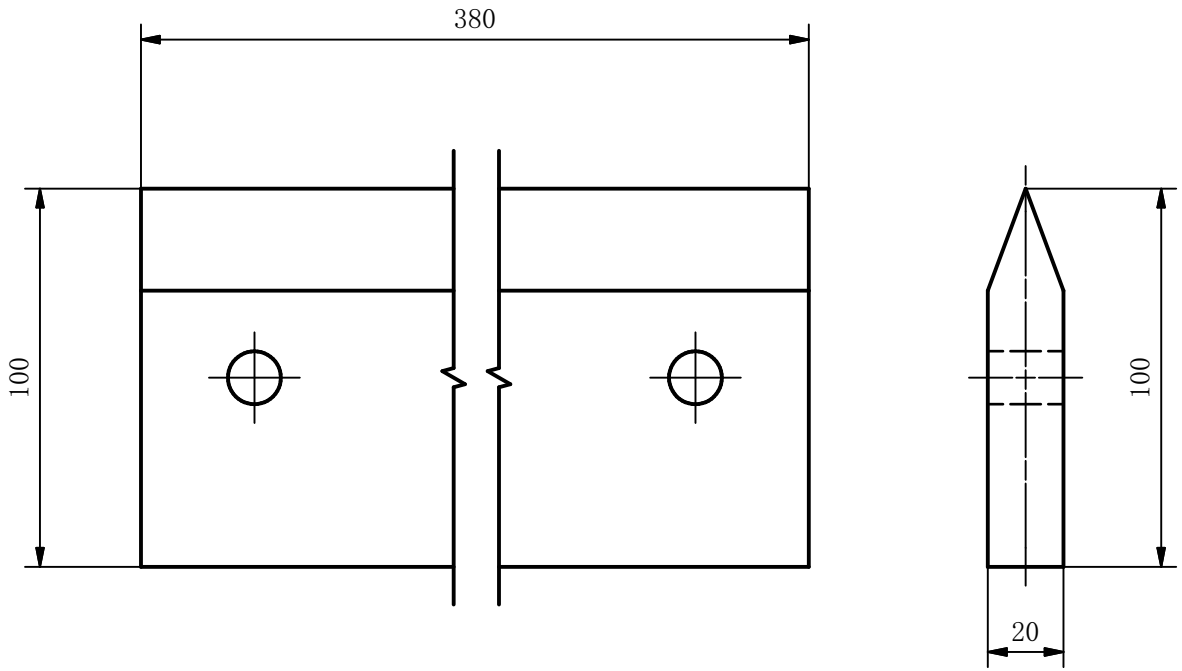

Technical Requirements:

1. Position size tolerance: 1.5mm;
2. Clean the burr;
3. The top two inclined planes should be smooth and not accumulate dust;
4. Rated working voltage: 80kv;
5. Working temperature: 200° C;
6. a material; SFB-1, in line with QB/T 3625-1999 standard;
7. Purchase and cut according to the size, planing the groove, marking and drilling.

1

1

1

2

3

4

A4

本图及所含的技术信息，为艾尼科环保技术（安徽）有限公司所有，受法律保护，
 事先未经本公司书面许可，不得以任何方式描绘、复制、用于其他工程、提供或披露给第三方。
 THIS DRAWING AND THE TECHNICAL INFORMATION IT CONTAINS ARE THE PROPERTY OF EETC . IT MUST NOT BE
 TRACED, COPIED, OR USED IN OTHER PROJECT NOR DISCLOSED TO ANY THIRD PARTY WITHOUT OUR WRITTEN CONSENT.