

会
标
SIGN

本图及所含的技术信息，为艾尼科环保技术（安徽）有限公司所有，受法律保护，
 事先未经本公司书面许可，不得以任何方式抄袭、复制或用于其他工程。提供或披露给第三方。
 THIS DRAWING AND THE TECHNICAL INFORMATION IT CONTAINS ARE THE PROPERTY OF EETC. IT MUST NOT BE
 TRACED, COPIED, OR USED IN OTHER PROJECT NOR DISCLOSED TO ANY THIRD PARTY WITHOUT OUR WRITTEN CONSENT.

A3

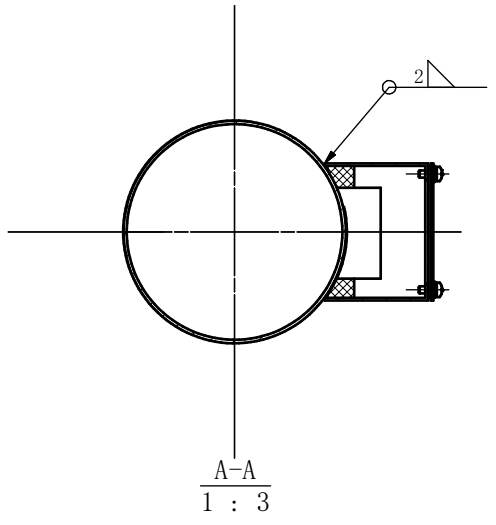
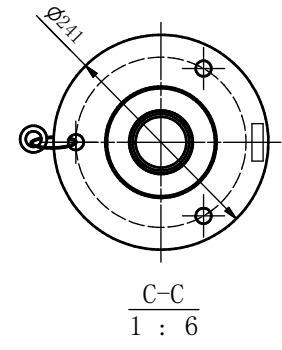
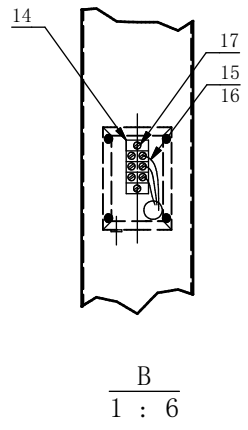
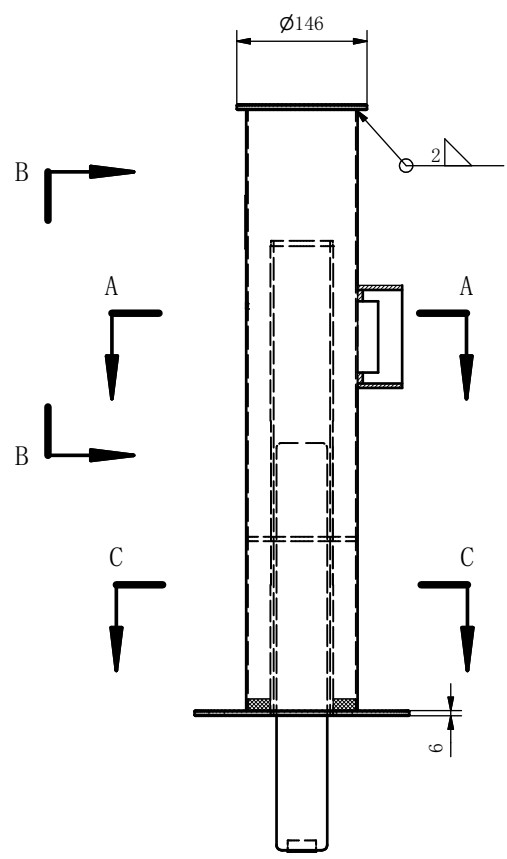

Technical requirements:

- 1、The contact between the insulated lead and the coil must be completely embedded in the epoxy resin and sealed with epoxy resin. The area where the lead wire passes through the barrel. The junction box has a minimum degree of protection of IP55;
- 2、The outer surface of the rapper is painted, see the paint specification for details, and the trademark is pasted after the topcoat is dried;